

CONCRETE PATHWAYS - PART PLAN

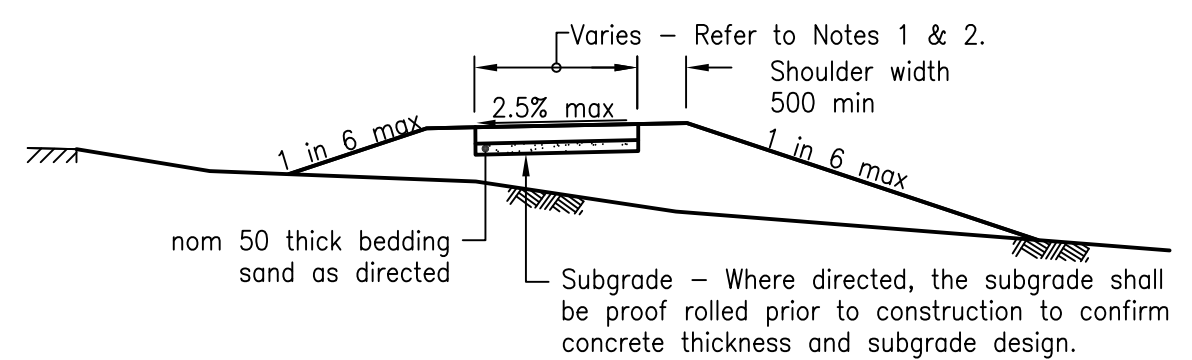

TYPICAL SECTION
(Where no kerb & channel exist)

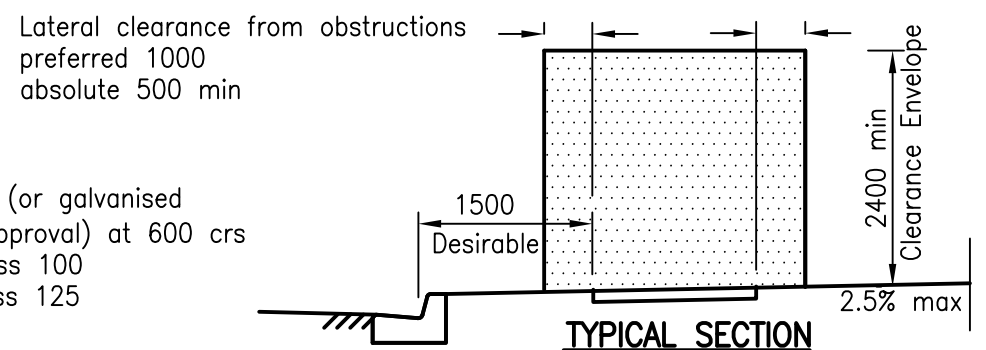

TYPICAL SECTION
(Where kerb & channel exists)

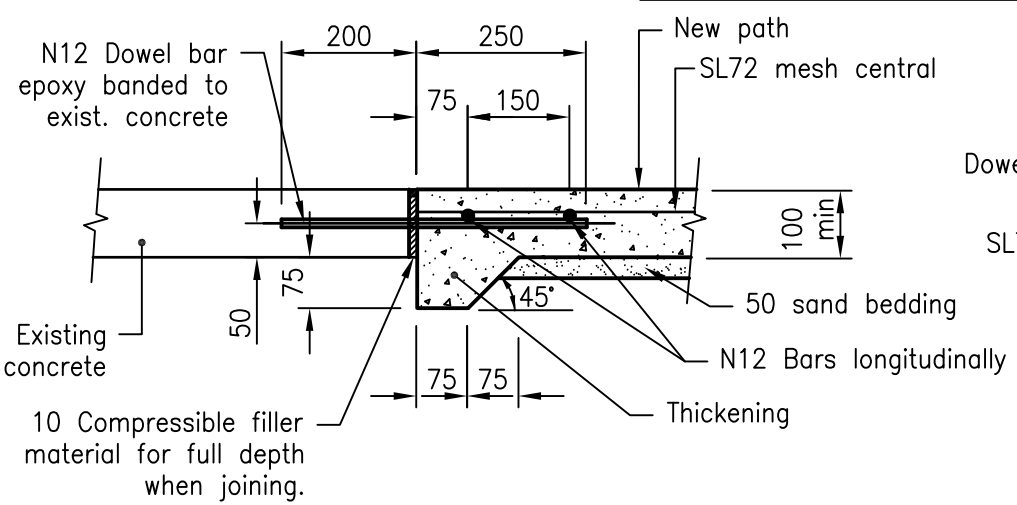

PATHWAY WIDENING/JOINING
(minimum widening 800)

Dowel bars to be placed along the pathway midway between joints at 2000 crs, or as directed by the relevant Council

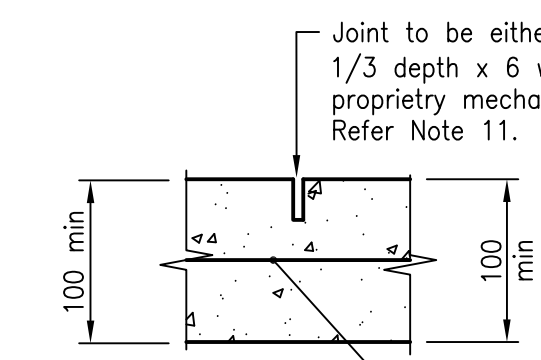

CONTROL JOINT (CJ)
Shown C.J. on plans

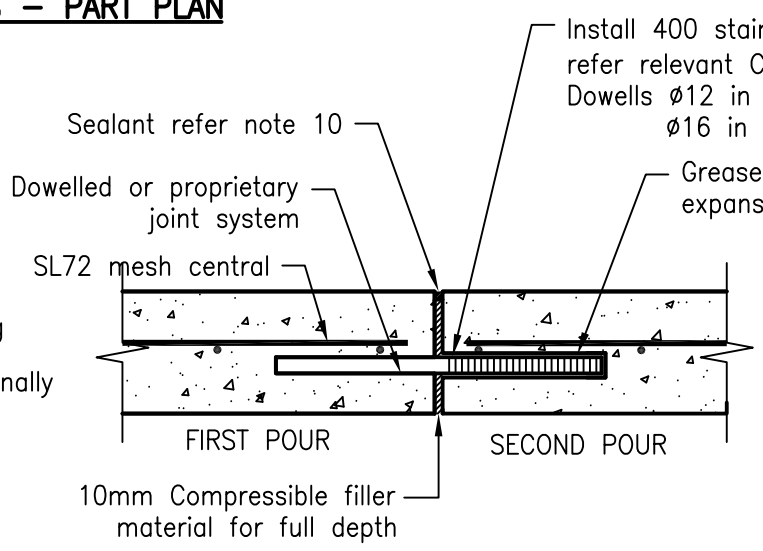

DOWELLED EXPANSION JOINT DETAIL (DEJ)

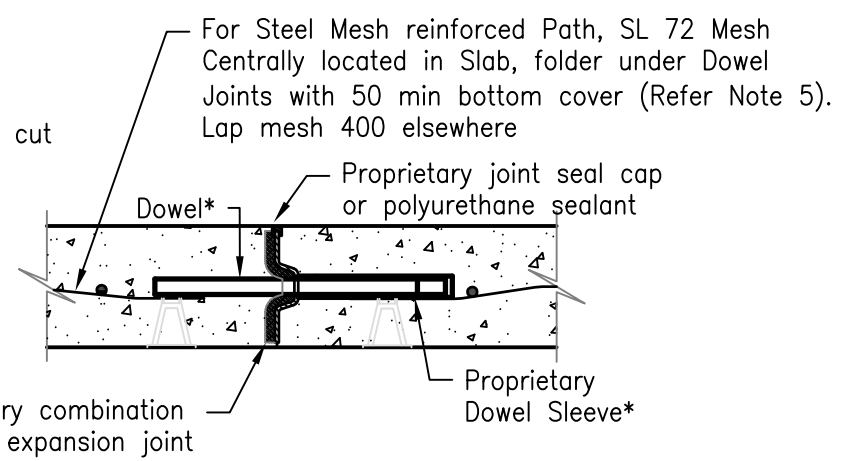

DETAIL 'A'
PREFORMED KEY JOINT WITH DOWEL
* Dowel maybe eliminated for mass concrete paths

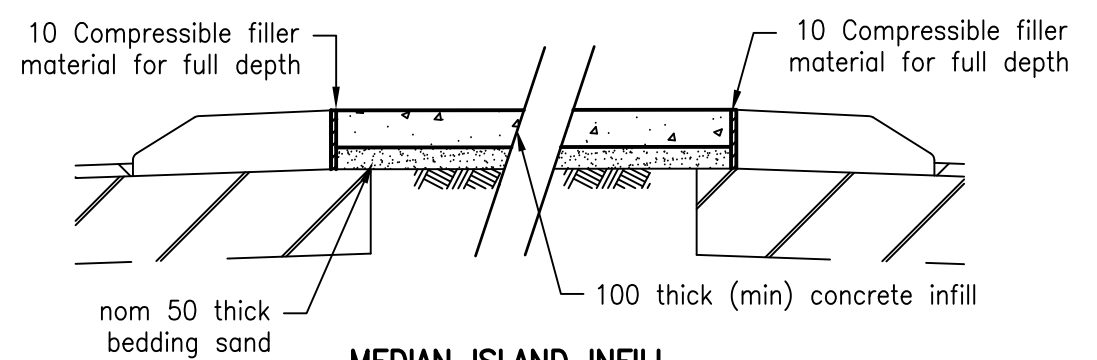

MEDIAN ISLAND INFILL

NOTES:

1. Refer to relevant Council requirements for pathway width, dimensions and concrete colour.
2. Concrete to be grade N32 AS 1379 and AS 3600 unless approved otherwise.
3. Reinforcing requirements may be amended on written instructions from Council.
4. Fibre reinforcement - When approved for use by the relevant Council, the concrete shall be reinforced with Class 2 macro structural synthetic polymer fibres in accordance with the manufactures specification for the specified design load.
5. For steel mesh reinforced paths at dowelled expansion joints: Mesh is to be stopped 75 from the joint, be placed under the dowels and chaired at min 50 cover from bottom to deter the mesh deflection interfering with the Dowels.
6. Surface to be non-slip concrete finish to AS 1428.1.
7. The dimension between kerb invert and edge of pathway may be varied subject to relevant council approval. For appropriate treatment of grades greater than 1 in 8 (12.5%), refer to AS 1428, Design for access & mobility.
8. Where a vehicle crossing point, or path is subject to longitudinal traffic the pathway details shall be per relevant residential driveway standard details RS-050.
9. Additional path details shall be as per Austroads Guidelines.
10. Expansion joints to be sealed with a low modulus self priming sealant to the manufacturers specifications. The colour of the sealant is to match the adjoining surface finish.
11. Saw cut joints are to be undertaken between 4 to 12 hours after laying depending on conditions. Joint sealant is required in sandy areas.
12. All dimensions are in millimetres unless shown otherwise.

These drawings have been developed in consultation between the participating Councils. BEFORE USE, the user shall confirm that the drawing has been adopted by the relevant Council.

F	03/14	Amended Drawing Number
E	12/11	Drawing Number changed from SEQ R-065 to RS-065
D	06/11	Review
C	06/10	Review
B	06/09	Review
G	06/14	Review
Rv.	DATE	REVISIONS
	09/08	ORIGINAL ISSUE



INSTITUTE OF PUBLIC WORKS ENGINEERING AUSTRALASIA
STANDARD DRAWINGS

PATHWAYS
CONCRETE PATHWAY
CONSTRUCTION DETAILS

RS-065

F
E
D
C
B
G
Rv.