

SECTION B - B

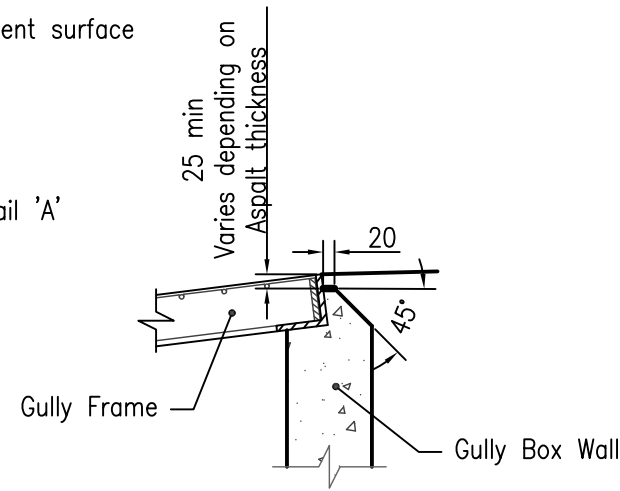

DETAIL A

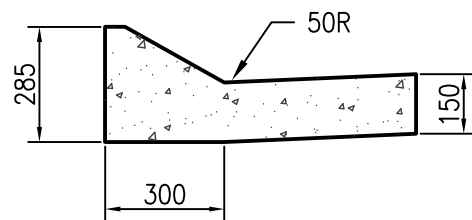

SECTION C - C

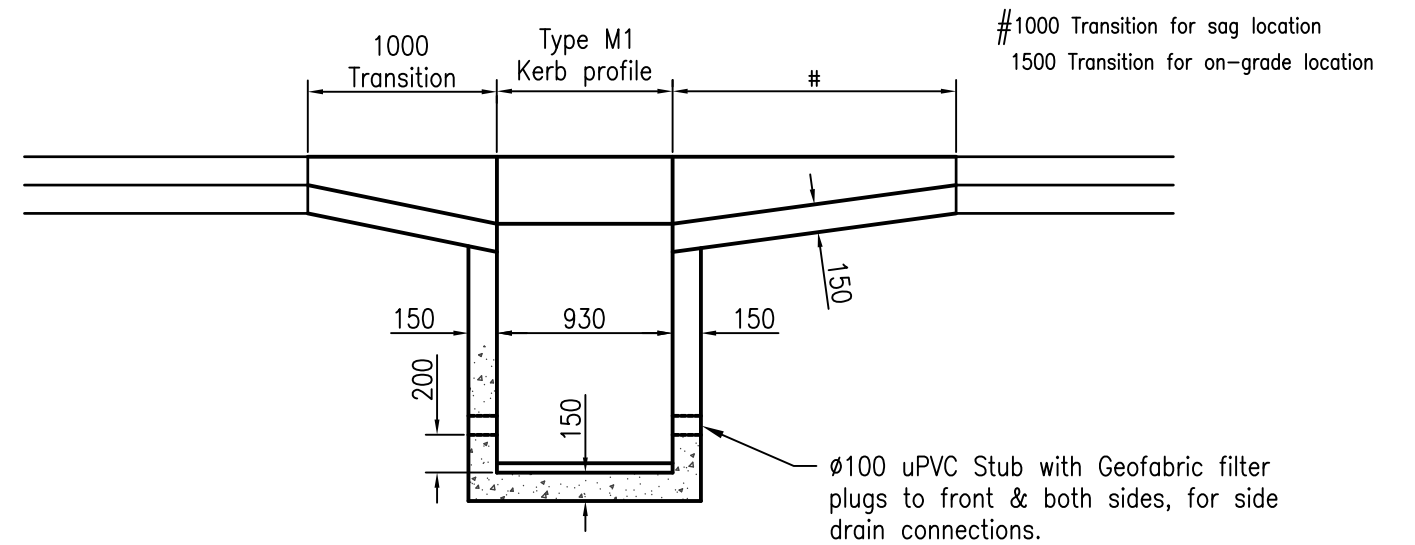

SECTION A - A

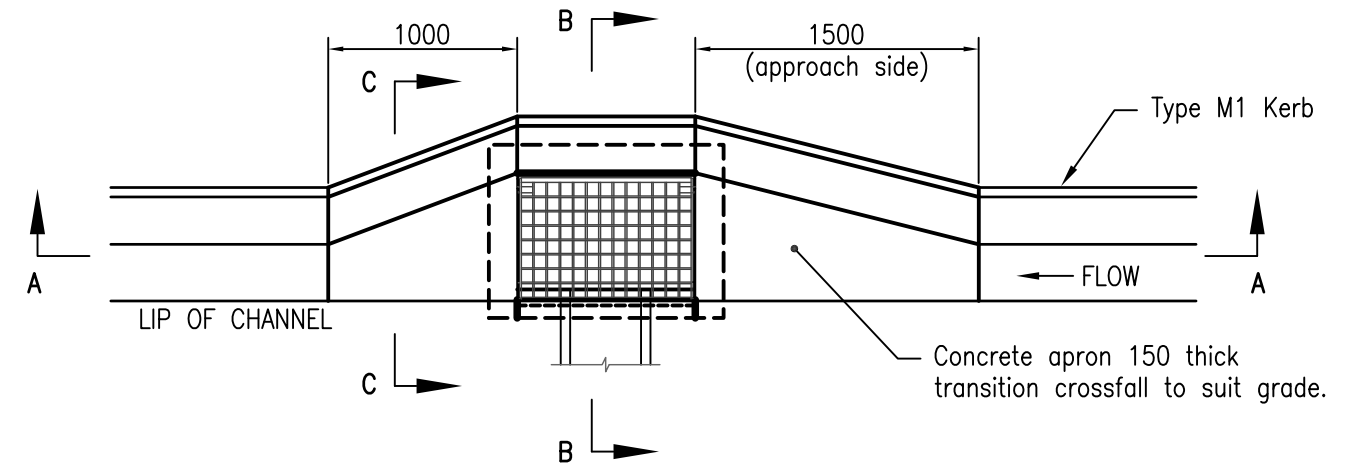

TYPICAL INLET ON GRADE

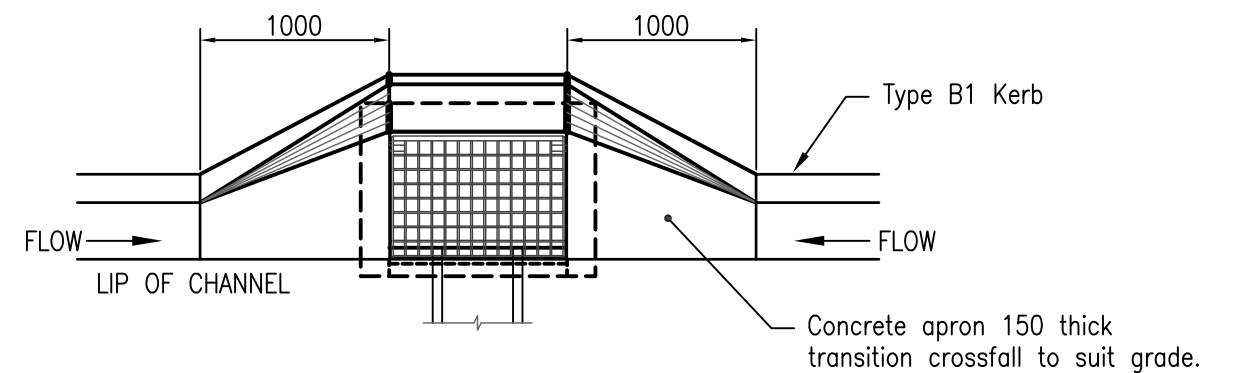

TYPICAL INLET IN SAG

NOTES:

1. Refer RS-080 for Kerb Profile Details
2. Cast in-situ concrete N32 to AS 1379 and AS 3600.
3. Refer DS-062 for Gully Grate and Frame details.
4. Capture in this Gully not to be included in Hydraulic calculations. This Gully only to be used for drainage carriageway.
5. All dimensions are in millimetres unless shown otherwise

These drawings have been developed in consultation between the participating Councils.
BEFORE USE, the user shall confirm that the drawing has been adopted by the appropriate Council.

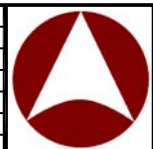

**INSTITUTE OF PUBLIC WORKS ENGINEERING AUSTRALASIA
STANDARD DRAWINGS**

**DRAINAGE PITS
KERB INLET - KERB IN LINE
ANTI PONDING**

DS-068

Rv.	DATE	REVISIONS
B	06/14	Review
A	10/12	Original Issue

B	A	Rv.