

2-R6 bars Grade 400 to AS 1302, placed centrally in ring with 40 side cover. Lap 250.

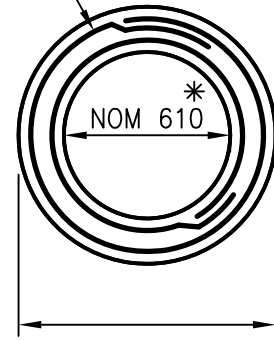

Overall diameter nom 1050\*  
Concrete thickness 35 or 50

**ROOF RING PLAN**

For use in raising covers and frames of existing access chambers  
\* Size to suit existing access chamber

Approved cast iron cover and frame complied to AS 3996, Refer to DS-015, DS-019 & DS-020

Precast roof slab to manufacturers specification or RPEQ Design

Ø100 uPVC slotted pipe stub, 1000 long with end cap, installed on the upstream side of access chamber (unless directed otherwise) The stub is required to dewater the pipe trench.

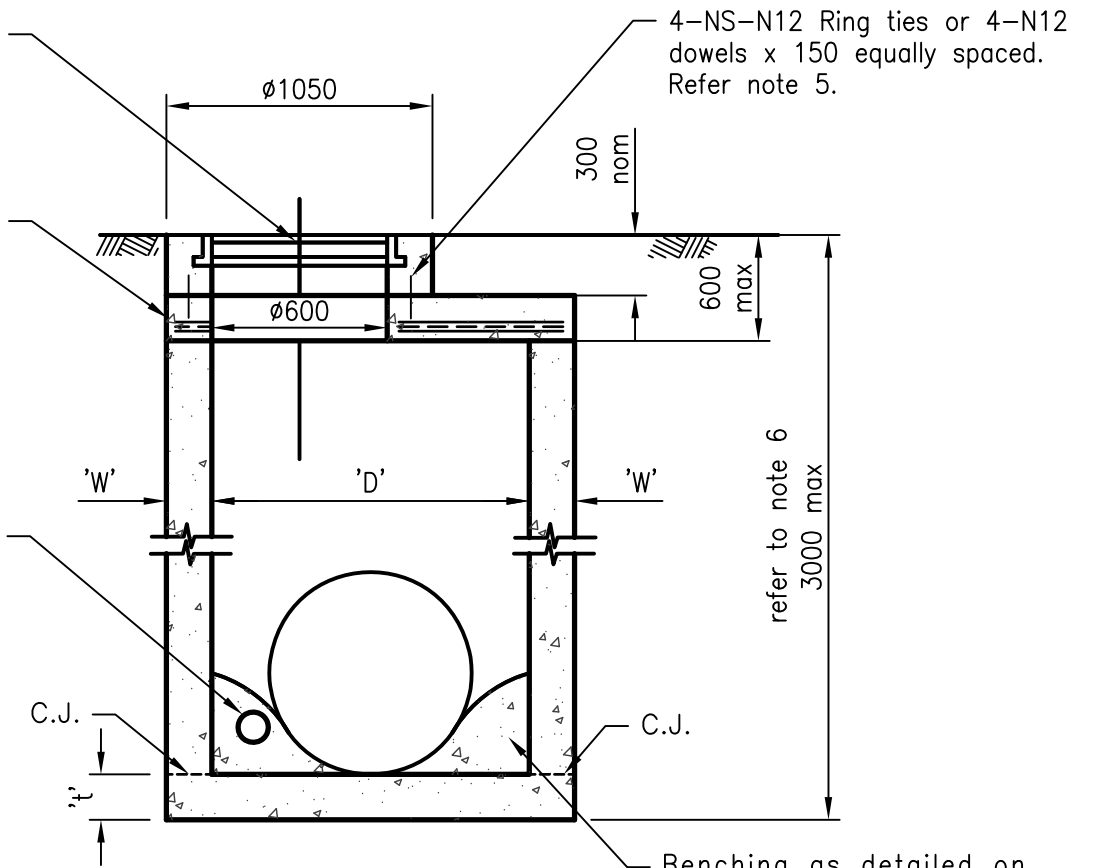

**ACCESS CHAMBER DETAILS SECTION**

Benching as detailed on project drawings or directed by relevant Council.

**DIMENSION**

Access chamber DIA 'D'	FLOOR THICKNESS 't'		Wall thickness 'W'	Roof/Floor slab DIA
	INLET	OUTLET		
1050	175	150	150	1350
1200	250	225	225	1650
1350	250	225	225	1800
1500	250	225	225	1950
1800	250	225	250	2300
2100	275	250	275	2650

**NOTES:**

- Concrete: Benching N25, Structural N40 (precast), N32 (Cast insitu) in accordance with AS1379 and AS 3600.
- Access chambers which are proprietary items are required to be designed and certified to AS 3996-1992. Access covers subject to road traffic shall be of Class D design, where Minimum Ultimate Limit State Design Load = 210kN. Access covers subject to pedestrian traffic and occasional vehicle load shall be of Class C design, where Minimum Ultimate Limit State Design Load =150kN. (Ref: AS 3996-1992 and Austroads Bridge Design Code 1992).
- Cover and frame, gray cast iron, Grade > T220 to AS 1830.
- Refer Project Drawings for size and level of culverts, chamber cover level and setout point details.
- Precast manhole top slabs are to be supplied with four (4) factory installed ring ties or alternately dowel bars may be accepted, subject to approval from the relevant Council.
- Manholes deeper than 3000 require individual design and certification.
- All dimensions are in millimetres unless shown otherwise.

These drawings have been developed in consultation between the participating Councils. BEFORE USE, the user shall confirm that the drawing has been adopted by the appropriate Council.

Rv.	DATE	REVISIONS
D	06/14	Review
C	03/14	Amended Drawing Number
B	11/12	Concrete Strength Amended
A	10/12	ORIGINAL ISSUE



**INSTITUTE OF PUBLIC WORKS ENGINEERING AUSTRALASIA  
STANDARD DRAWINGS**

**STORMWATER ACCESS CHAMBER DETAIL  
1050 TO 2100 DIAMETER**

**DS-010**

D  
C  
B  
A  
Rv.