

LOCKING RAIL TYPE 1

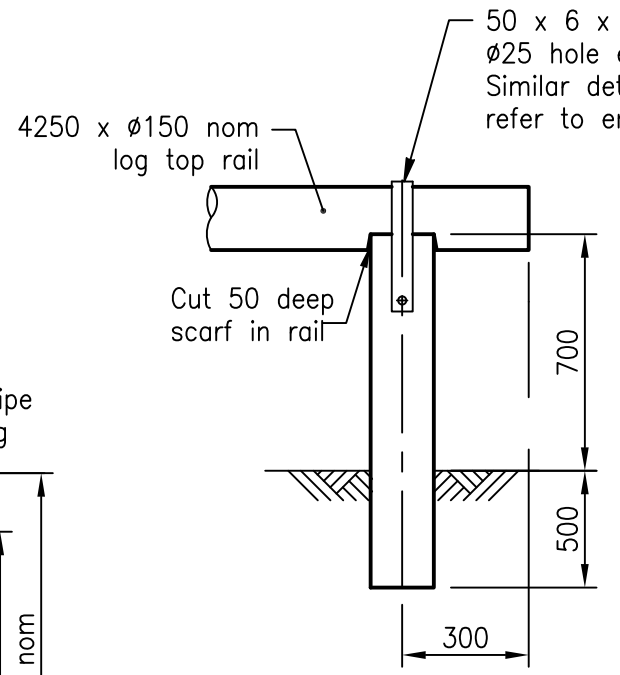

ELEVATION

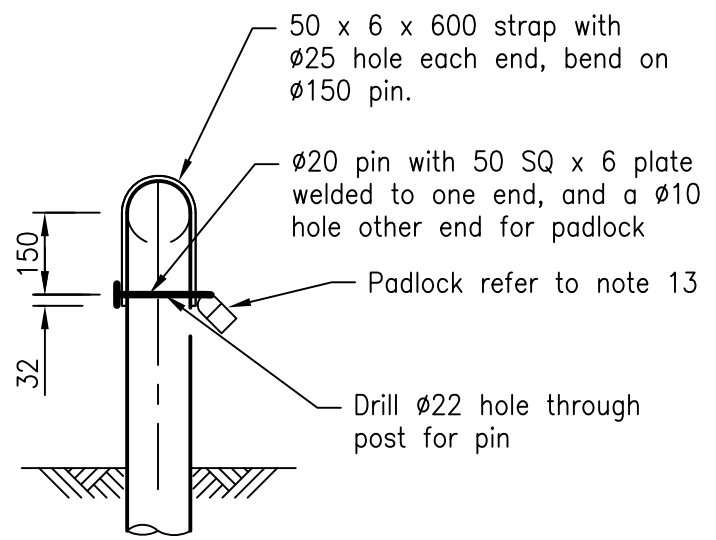

END ELEVATION

LOCKING RAIL TYPE 2

NOTES:

1. All pipes medium black tube to AS 1074.
2. All welds to AS 1554.
3. All welding symbols to AS 1101.3.
4. Steel plates to be Grade 250 to AS 3678.
5. Bar and channels to be Grade 250 to AS 3679.
6. All fabricated work, including plate key, shall have smooth ground edges.
7. All steelwork to be hot dipped galvanised after fabrication to AS 4680.
8. Concrete N25 in accordance with AS 1379 and AS 3600.

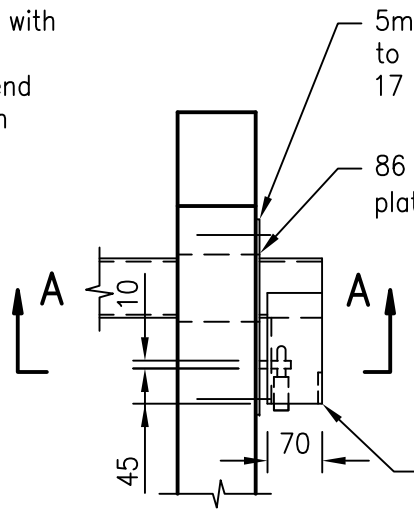

DETAIL A

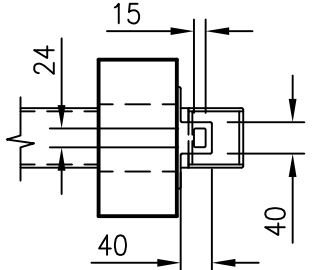

SECTION A-A

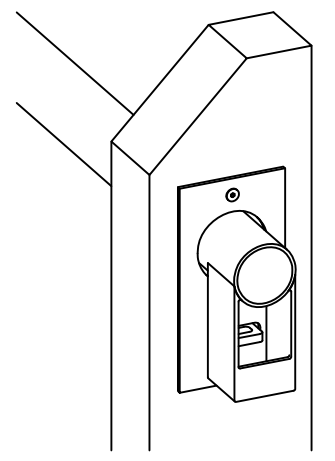

ISOMETRIC VIEW

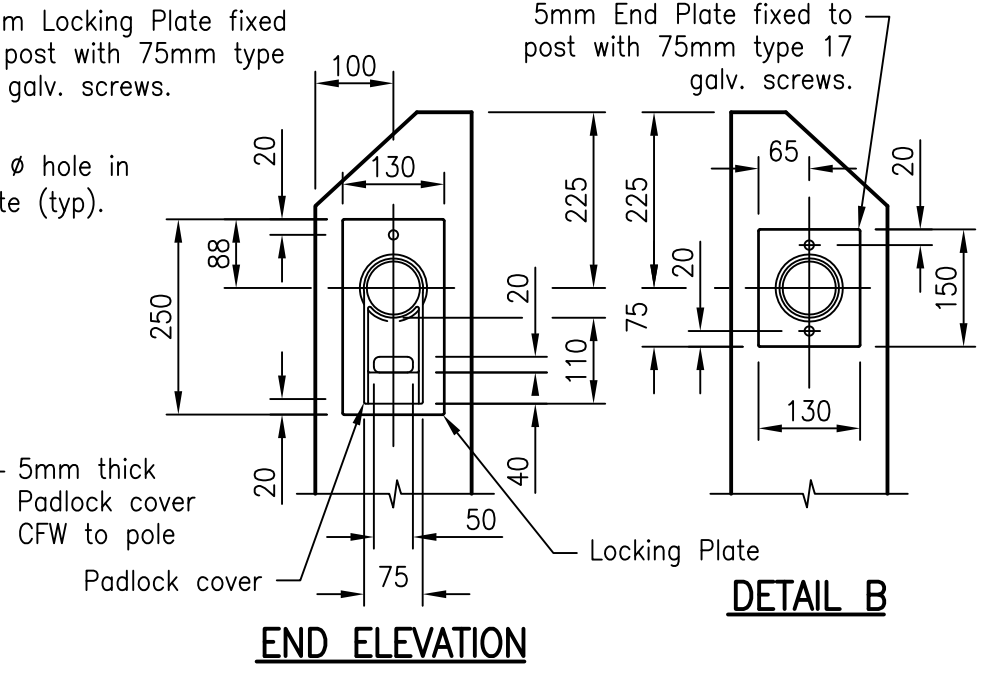

END ELEVATION

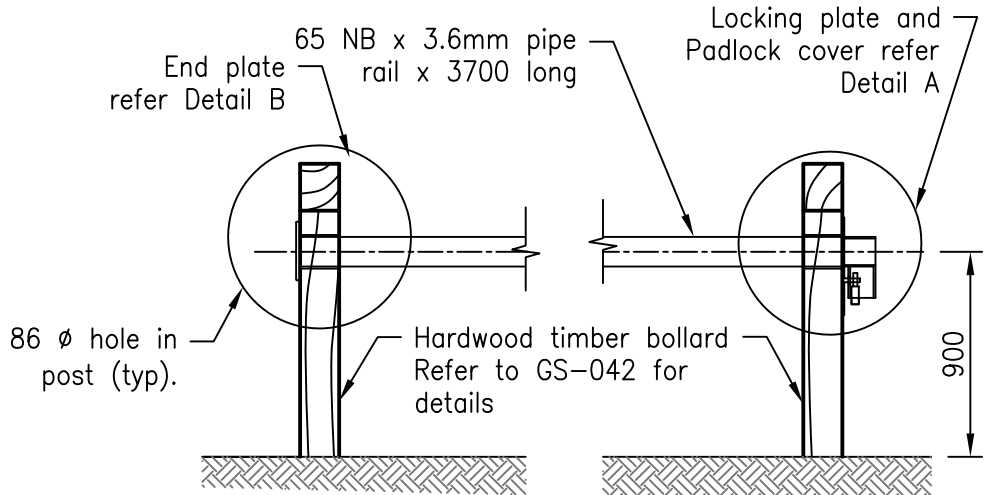

ELEVATION

LOCKING RAIL TYPE 3

9. Log Barriers to be 150 dia. Grade A treated to AS 1604.
10. Use of CCA treated timber to be approved by relevant Council prior to installation.
11. Paint all cut CCA surfaces with industrial clear water repellent to lock chemicals used on CCA, in accordance with AS 1607.
12. All hardwood timber to be Durability Class 1 F14, preservative treated to H5.
13. Refer to relevant Council for supply of approved locking system.
14. Locking rail to be painted yellow (Safety) or as specified.
15. All dimensions are in millimetres unless shown otherwise.

These drawings have been developed in consultation between the participating Councils. BEFORE USE, the user shall confirm that the drawing has been adopted by the appropriate Council.

Rv.	DATE	REVISIONS
E	06/14	Review
D	03/13	Amended Drawing Number
D	03/13	Drawing number changed & Type 2 Rail height amended
C	06/11	Review
B	06/10	Review
F	11/15	Isometric View added



INSTITUTE OF PUBLIC WORKS ENGINEERING AUSTRALASIA
STANDARD DRAWINGS

FENCING
LOCKING RAIL
TYPES 1, 2 & 3

GS-043

F
E
D
C
B
A
Rv.